

CR100 Solarimeter

KIMO[®]
INSTRUMENTS



Photovoltaic mode

Global sensor of solar radiation

Dedicated to monitor the proper operating of plants using solar radiation :

- Hot water production
- Photovoltaic electricity production
- Applications in agronomy
- Meteorological monitoring
- ...

Sends 0-10 V or 4-20 mA analogue signal proportional to the radiated solar power

via the interface module connected to a PLC or a data acquisition system.

Allows monitoring of plants performance

Removable, it can be periodically adjusted to guarantee measurement accuracy.

For QualiSOL, QualiPV certificated professionals and control office for the Guarantee of Solar Result.



0-10 V or 4-20 mA outputs



CR100 Solarimeter



0-10V output - Active

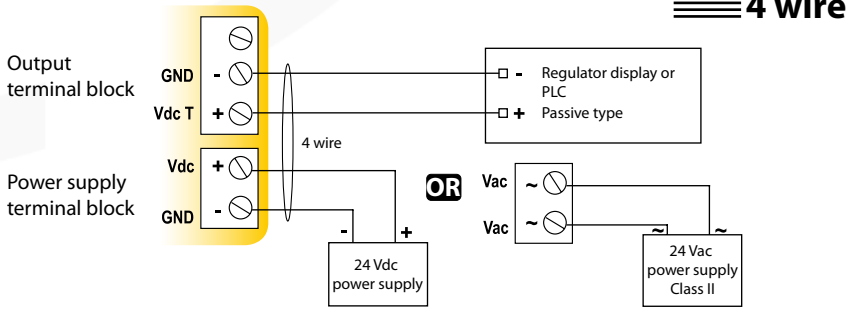

4-20 mA output - Passive

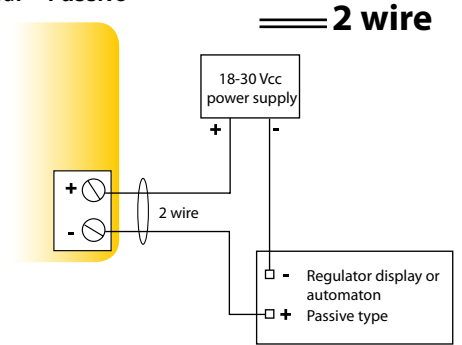

For a 3 wire connection, before power up, connect ground output with ground input. Eg : wiring diagram above .

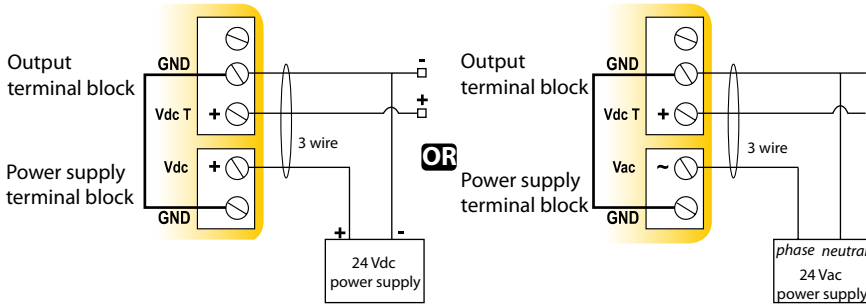

OR

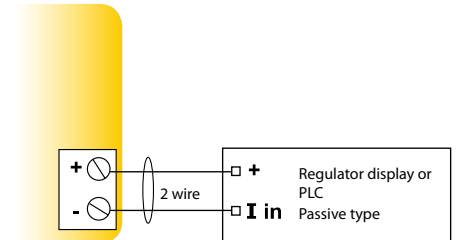

Technical features

Interface module

- Output / Power supply :
 - CR101 0-10 V active sensor
10 % 24 Vac/Vdc power supply, 3-4 wire
 - CR100 4-20 mA passive loop sensor
18/30 Vdc power supply, 2 wire
- Peak load : 500 Ohms (4-20 mA)
- Minimum load : 1 K Ohms (0-10 V)
- Consumption : 2 VA (0-10V) or 22 mA (4-20 mA) max.
- Electromagnetic compatibility : EN 61326
- Electrical connection : terminal block with screw for cables of 1,5 mm² max.
- Operating temperature : from -20 to +50°C
- Housing : ABS
- Fire class : H-B as per UL94
- Housing overall dimensions : 100x100x42 mm
- Protection : IP65
- Wiring grommet : for cables of 7 mm max.
- Weight : 110 g



Supplied with calibration certificate



Solar cell

- Measuring range : from 0 to 1300W/m²
- Spectral response : from 400 to 1100 nm
- Nominal sensitivity : 100mv for 1000W/m² STC*
- Response in cosine : corrected until 80°
- Coefficient in temperature : +0,1%/°C
- Effective area : 1 cm²
- Operating temperature : from -30° to +60°C
- Humidity dependence : 100%RH
- UV performance : excellent (PMMA filter)
- Mode : photovoltaic
- Material : polycristallin silicon
- Front face : translucent PMMA
- Tightness : Polyurethane resin and housing in PMMA and polyacetol
- Cell weight : 60g
- Cell dimensions : 30 x 32mm

*S.T.C : Standard Test Conditions
25°C - Solar spectrum AM 1,5

Supplied with

- Sensor and 5 m cable
- Interface module
- Correspondence certificate of levels for adaptation to the data acquisition system.

Optional

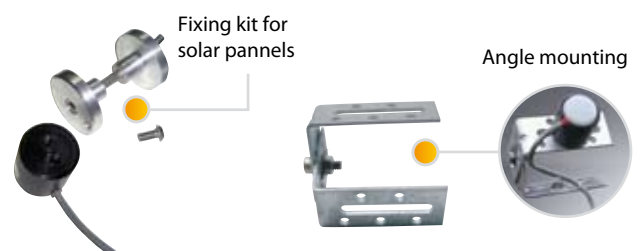

www.kimo.fr

Distributed by :

EXPORT DEPARTMENT

Tel : + 33. 1. 60. 06. 69. 25 - Fax : + 33. 1. 60. 06. 69. 29

e-mail : export@kimo.fr

